



# HGS (INDIA) LIMITED



## 5515 Panel Mount Connector Assembly with Ferrite Bead & Molex Connector



158, Sector-4, IMT Manesar, Gurugram-122050, Haryana, INDIA  
Tel: +91 (0124) 4681800  
Email: sales@hgsindia.com



# HGS (INDIA) LIMITED



## SCHEMATIC

### 5515 Panel Mount Connector Assembly with Ferrite Bead & Molex Connector

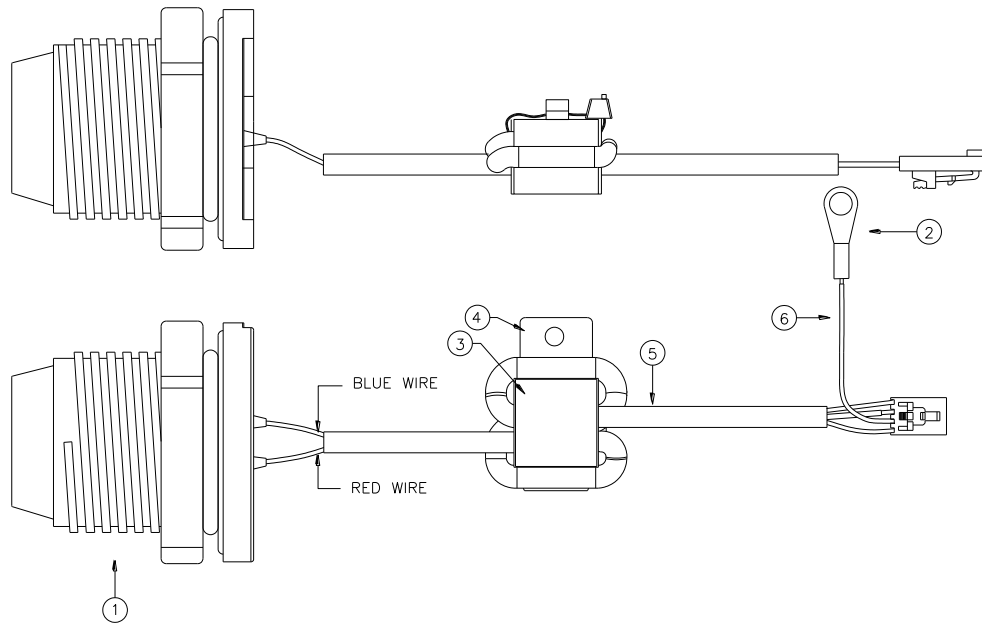

6	PVC WIRE, 24AWG, GREEN	SI0125	14.02cm
5	CBL 2 COND. WIRE, 30AWG, SHLD	CB1049	27.43cm
4	CABLE TIE METAL MOUNTING BASE	CM1195	01No.
3	FERRITE BEAD 940hm@100MHZ Axial 11x6.75x15	CM1194	01No.
2	RING LUG UNISUL 26-22AWG #6	CM0232	01No.
1	5515 PANEL MOUNT CONN. ASSY.	AJ0139	01No.
SL. NO.	DESCRIPTION	P/N	QTY.

158, Sector-4, IMT Manesar, Gurugram-122050, Haryana, INDIA

Tel: +91 (0124) 4681800

Email: sales@hgsindia.com



# HGS (INDIA) LIMITED



## SPECIFICATIONS

### 5515 Panel Mount Connector Assembly with Ferrite Bead & Molex Connector

- Female connector with 1 set of male and female contacts
- Ferrite bead for suppression of high frequency noise
- Threads provided for mating with its counterpart male connector with coupling
- Screw fit mating
- Impact resistant material
- Water proof for marsh environment
- Gold plated pins & sockets assure positive electrical connections
- Maximum strength in rugged field condition
- Operating temperature range: -20°C to +70°C
- Pressure Rating: Up to 1.5 bar

Version 1.2